

SCOPE OF SUPPLY

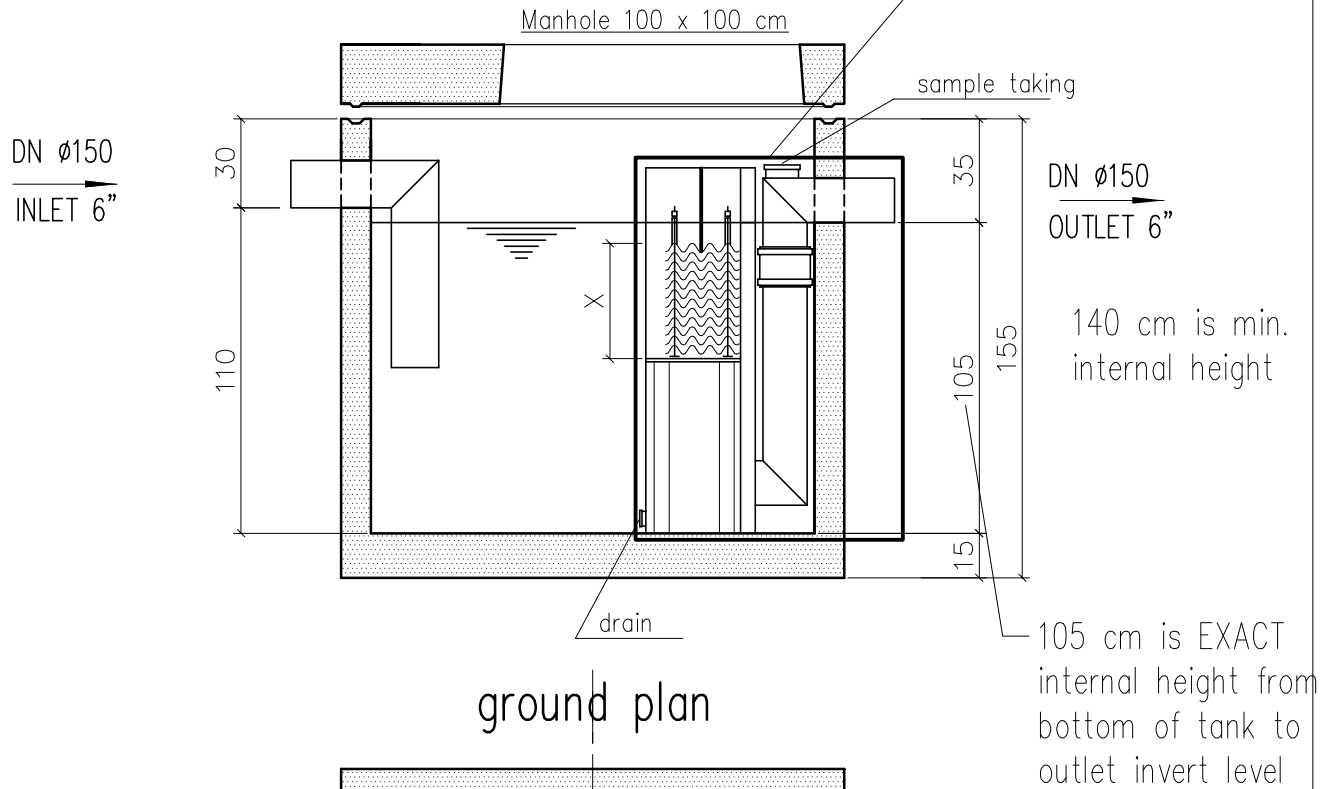

ground plan

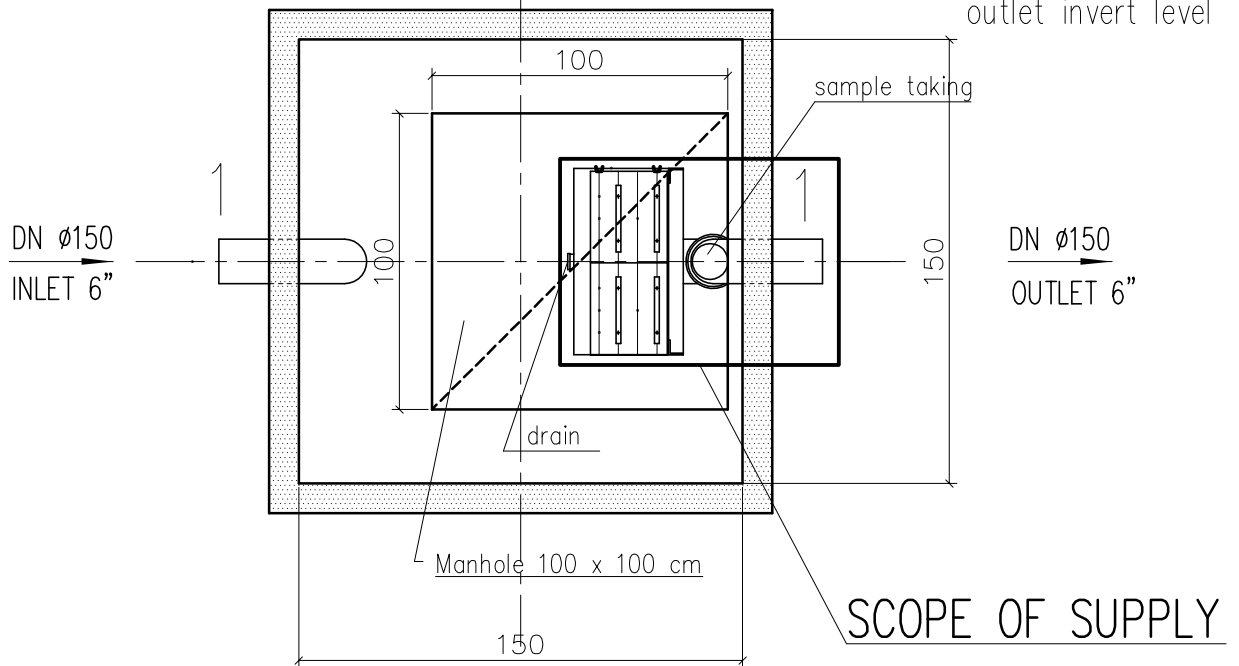

Model	plate pack height X	NS	flow rate
2 EBSRE-1,6	26	2	2 l/sec
3 EBSRE-1,6	39	3	3 l/sec
4 EBSRE-1,6	52	4	4 l/sec
5 EBSRE-1,6	65	5	5 l/sec
6 EBSRE-1,6	78	6	6 l/sec
8 EBSRE-1,6	98	8	8 l/sec

measurements in cm!

date:	name:	<b>PREVIT</b>	type:				
constr.: 09.01.2009	Mei		EBSEE NS2-NS8				
contr.:			drawing no.:				
MINERAL-OIL AND RESIDUAL-OIL SEPARATOR		including silt chamber, volume 1800 liters			2-8EBSEE-1,8-UA		
					modif.:	a	b
		date:			23.01.09	06.10.11	